

---

# Fire Safety Ratings

## Understanding Fire Ratings

The following are provided as general information on Fire Ratings in building construction as they pertain to GasPex and WaterPex installations.

IN ALL CASES please refer to the full transcript of our Fire Test reports to ensure that fire rated silicone and fire collars are suitable for use with our products to achieve the fire rating that is required for the nominated building specification.

### Some Basic Information

1. A Fire Rated Duct is exactly that. It is generally a riser duct that has been constructed to achieve the fire rating required for that situation.
2. All other riser ducts have not been constructed to achieve a specific fire rating for the building and Fire Collars or Fire Rated silicone or similar will be required to be used for each service penetrating a wall or floor.
3. (Floor) Riser Ducts are typically required to have a 4 hour fire rating.
4. Walls are typically required to have a 2 hour fire rating.

## Australian Standards (AS1530-4) for Fire Rating and the Building Code of Australia

AS1530-2005 is THE Australian Standard for Methods for fire tests on building materials, components and structures. The objective of the Standard is to provide building designers, manufacturers, test laboratories and regulatory authorities with a set of uniform requirements for heating conditions, test procedures, and criteria for the determination of fire resistance of an element of building construction. This Standard is referenced in the Building Code of Australia and Part 4 of this Australian Standard details the Fire-resistance testing of elements of Construction. This covers testing of fire resistance that relates to installation of pex systems in buildings including GasPex and WaterPex.

The Cousta Group has comprehensive testing of its products with fire collars and fire rated silicones conducted in accordance with this Standard. This information is available on request.

## The Essence & Implications of Fire Tests as per AS1530-4

AS1530-4 is primarily concerned as to what happens in a building should there be a fire. It particularly considers the following:

1. Will the Structural Integrity of the Building be compromised?
2. Will the fire collar, silicone or other similarly functioning element stay intact and close o the penetration through wall or floor in the event of fire? It must not crack or open so that it prevents transfer of flame, smoke or other through walls, floors and ceilings.
3. Will the fire collar, silicone or other similarly functioning element provide sufficient insulation against heat between each side of the wall, floor or ceiling?

A test assembly is prepared utilizing the materials intended to be used to construct the actual internal walls or floor of the building, the brand of piping intended to be installed and a range of fire resisting options for the wall penetrations such as fire collars, fire proof silicone and the like.

A furnace is set up on one side of the test wall and the fire resistance performance of wall and penetrations monitored. Throughout the course of the test, observations are made of the behavior of the assembly with particular emphasis on structural adequacy, integrity and insulation. All significant events are recorded and the time of their occurrence noted.

The test results are stated in terms of the time elapsed from the start of the test until failure occurs in each of the items of Structural integrity, and Integrity and insulation of the penetration.

The results are expressed as a Fire Resistance Level (FRL) and are shown in the form of xx/-/- for a structural beam or column or -/yy/zz for a non load bearing wall. The -/yy/zz format is that which is applicable to pex systems. In -/yy/zz, the "-" refers to the structural integrity, the "yy" refers to the integrity of the penetration and the "zz" refers to insulation effectiveness of the penetration.

## Interpreting FRL's

If a wall or floor is required to have a 4 hour fire rating, the integrity and insulation of the penetration must not fail within 4 hours of testing as conducted in accordance with AS1530-4. Both integrity and insulation are equally important.

So for a 4 hour rating we would expect the test report to show a FRL of -/240/240 where 240 represents 240 minutes or 4 hours.

If a test report showed an FRL of -/90/120, this would indicate that the FRL of the integrity of the penetration (fire collar or silicone) is 90 minutes (one-and-a-half hours) and the FRL related to the insulation is 120 minutes (2 hours).

The FRL of the penetration is 90 minutes, which is the lower number in the above example.

The following pages show summary results of FRLs for a range of fire collars and sealants. In assessing whether any collar or sealant is compatible with GasPex or WaterPex products and the specific installation requirements, FULL reports should be requested and assessed. All reports are available on request.

# Fire Safety Ratings

## Likely Fire Resistance of Concrete, Plasterboard and Masonry Floors and Walls With SNAP Fire Collars

Refer to CSIRO Assessment number FC)-2719 available on the SNAP Fire Collar web site at

[http://snapcollars.com.au/uploads/fsp1339\\_gas\\_floor\\_1.pdf](http://snapcollars.com.au/uploads/fsp1339_gas_floor_1.pdf)

Based on the observed performance during full scale penetration testing it is the opinion of the division of CSIRO that the systems tabulated below comprising GasPex, WaterPex, HeatPex and ChillPex PEX-AL-PEX composite pipes would be capable of achieving the designated fire resistance levels if tested in accordance with AS1530.4:2005.

Collar	Pipe sizes				Frl	System	Element
SNAP32GAS	16	20	25	32	-/240/240	Retro-fit	Concrete**
SNAP50GAS	32	40	50		-/240/240	Retro-fit	Concrete**
SNAP50HGAS	32				-/240/240	Cast-in	Concrete**
SNAP50HGAS		40	50		-/240/180	Cast-in	Concrete**
SNAP63GAS	63				-/240/240	Retro-fit	Concrete**
SNAP32GAS	16	20	25	32	-/120/120	Retro-fit	Plasterboard*
SNAP50GAS	32	40	50		-/120/120	Retro-fit	Plasterboard*
SNAP32GAS	16	20	25	32	-/180/120	Retro-fit	Plasterboard*
SNAP50GAS	32	40	50		-/180/120	Retro-fit	Plasterboard*
SNAP32GAS	16	20	25	32	-/180/120	Retro-fit	Masonry***
SNAP50GAS	32	40	50		-/180/120	Retro-fit	Masonry***

### For Pex-b piping through Plasterboard Walls, refer to report FSP1634 - 32R available on the SNAP Fire Collar web site

\* The Designated FRL is where the system is installed into a plasterboard lined framed wall system with an FRL of either -/120/120 or -/180/180 with the FRLs of the penetration system is altered to match that of the wall system

\*\* The Designated FRL is where the system is installed into a concrete slab with an FRL of 240/240/240. For slab systems with lower FRLs the FRLs of the penetration system is lowered to match that of the slab

\*\*\* The Designated FRL is where the system is installed into a masonry or concrete wall with an FRL of either -/180/180 or 180/180/180. For masonry or concrete wall systems with lower FRLs the FRLs of the penetration system is lowered to match that of the slab.

# Fire Safety Ratings

## Likely Fire Resistance of 128mm Plasterboard Walls with Fire Pro M707 Sealant and Passive Fire GPFC Collars

The following shows the likely fire resistance performance of Passive Fire GPFC collars and Firepro M707 sealant protecting GasPex (pex/al/pex) pipe penetrations through a plasterboard wall tested in accordance with AS1530-4:2005 and assessed in accordance with AS4072.1:2005.

The test assembly comprised a section of plasterboard wall of nominally 128mm thickness comprised of 64mm Rondo steel studs faced on each side with 2 layers of 16mm thick fire rated plasterboard.

Service	Criteria	Result
16mm GasPex with Passive Fire GPFC-16 retro fit collar	Structural Adequacy	Not applicable
	Integrity	181 minutes
	Insulation	155 minutes
	<b>FRL</b>	<b>-/180/120</b>
16mm GasPex with Fire Pro M707 sealant	Structural Adequacy	Not applicable
	Integrity	181 minutes
	Insulation	138 minutes
	<b>FRL</b>	<b>-/180/120</b>
20mm GasPex with Fire Pro M707 sealant	Structural Adequacy	Not applicable
	Integrity	167 minutes
	Insulation	115 minutes
	<b>FRL</b>	<b>-/120/90</b>
20mm GasPex with Passive Fire GPFC-16 retro fit collar	Structural Adequacy	Not applicable
	Integrity	181 minutes
	Insulation	153 minutes
	<b>FRL</b>	<b>-/180/120</b>
25mm GasPex with Passive Fire GPFC-16 retro fit collar	Structural Adequacy	Not applicable
	Integrity	181 minutes
	Insulation	115 minutes
	<b>FRL</b>	<b>-/180/90</b>
32mm GasPex with Passive Fire GPFC-16 retro fit collar	Structural Adequacy	Not applicable
	Integrity	181 minutes
	Insulation	111 minutes
	<b>FRL</b>	<b>-/180/90</b>

# Fire Safety Ratings

## Likely Fire Resistance of 150mm Concrete Slab with Fire Pro M707 Sealant and Passive Fire GPFC Collars

The following shows the likely fire resistance performance of Passive Fire GPFC collars and Firepro M707 sealant protecting GasPex (pex/al/pex) pipe penetrations through a 150mm concrete slab tested in accordance with AS1530-4:2005 and assessed in accordance with AS4072.1:2005.

Service	Criteria	Result
16mm GasPex with Passive Fire GPFC-16 retro fit collar	Structural Adequacy	Not applicable
	Integrity	No Failure at 205 minutes
	Insulation	149 minutes
	<b>FRL</b>	<b>-/180/120</b>
16mm GasPex with Fire Pro M707 sealant	Structural Adequacy	Not applicable
	Integrity	181 minutes
	Insulation	138 minutes
	<b>FRL</b>	<b>-/180/120</b>
20mm GasPex with Fire Pro M707 sealant	Structural Adequacy	Not applicable
	Integrity	167 minutes
	Insulation	115 minutes
	<b>FRL</b>	<b>-/120/90</b>
20mm GasPex with Passive Fire GPFC-16 retro fit collar	Structural Adequacy	Not applicable
	Integrity	181 minutes
	Insulation	153 minutes
	<b>FRL</b>	<b>-/180/120</b>
25mm GasPex with Passive Fire GPFC-16 retro fit collar	Structural Adequacy	Not applicable
	Integrity	181 minutes
	Insulation	115 minutes
	<b>FRL</b>	<b>-/180/90</b>
32mm GasPex with Passive Fire GPFC-16 retro fit collar	Structural Adequacy	Not applicable
	Integrity	181 minutes
	Insulation	111 minutes
	<b>FRL</b>	<b>-/180/90</b>

# Fire Safety Ratings

## Likely Fire Resistance of 150mm Concrete Slab with Fire Pro M707 Sealant and Passive Fire GPFC Collars

The following shows the likely fire resistance performance of Passive Fire GPFC collars and Firepro M707 sealant protecting GasPex (pex/al/pex) pipe penetrations through a 150mm concrete slab tested in accordance with AS1530-4:2005 and assessed in accordance with AS4072.1:2005.

Service	Criteria	Result
16mm GasPex with Passive Fire GPFC-16 retro fit collar	Structural Adequacy	Not applicable
	Integrity	No Failure at 205 minutes
	Insulation	149 minutes
	<b>FRL</b>	<b>-/180/120</b>
16mm GasPex with Fire Pro M707 sealant	Structural Adequacy	Not applicable
	Integrity	No Failure at 205 minutes
	Insulation	163 minutes
	<b>FRL</b>	<b>-/180/120</b>
20mm GasPex with Fire Pro M707 sealant	Structural Adequacy	Not applicable
	Integrity	No Failure at 205 minutes
	Insulation	133 minutes
	<b>FRL</b>	<b>-/180/120</b>
20mm GasPex with Passive Fire GPFC-20 retro fit collar	Structural Adequacy	Not applicable
	Integrity	No Failure at 205 minutes
	Insulation	132 minutes
	<b>FRL</b>	<b>-/180/120</b>
25mm GasPex with Passive Fire GPFC-25 retro fit collar	Structural Adequacy	Not applicable
	Integrity	No Failure at 205 minutes
	Insulation	107 minutes
	<b>FRL</b>	<b>-/180/90</b>
32mm GasPex with Passive Fire GPFC-32 retro fit collar	Structural Adequacy	Not applicable
	Integrity	No Failure at 205 minutes
	Insulation	117 minutes
	<b>FRL</b>	<b>-/180/190</b>
40mm GasPex with Passive Fire GPFC-40 retro fit collar	Structural Adequacy	Not applicable
	Integrity	No Failure at 205 minutes
	Insulation	119 minutes
	<b>FRL</b>	<b>-/180/90</b>
50mm GasPex with Passive Fire GPFC-50 retro fit collar	Structural Adequacy	Not applicable
	Integrity	No Failure at 205 minutes
	Insulation	119 minutes
	<b>FRL</b>	<b>-/180/90</b>
63mm GasPex with Passive Fire GPFC-63 retro fit collar	Structural Adequacy	Not applicable
	Integrity	201 minutes
	Insulation	34 minutes
	<b>FRL</b>	<b>-/180/30</b>

# Fire Safety Ratings

## Promat FRLS

The following pages relate to the Approval for Promat fire collars (PROMASEAL CFC products) with GasPex and WaterPex branded pipes.

### GAS – (PEX-AL-PEX)

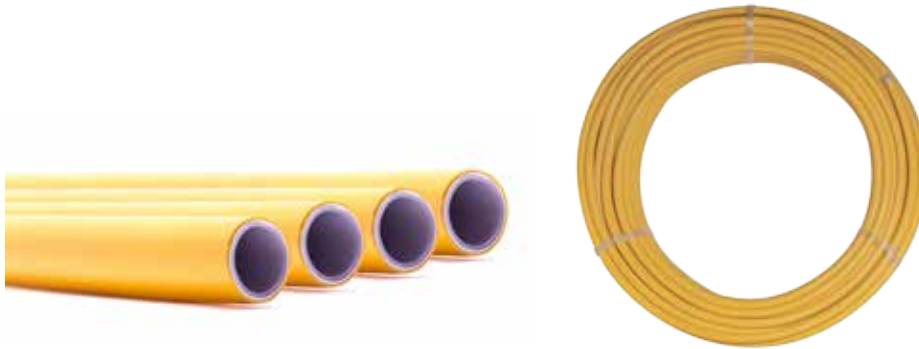

Gas (Pex-Al-Pex) piping

PIPE	Floor / Slab		Fire Rated Plasterboard (128mm Thick)		Fire Rated Plasterboard (96mm Thick)	
	RETRO-FIT COLLAR	FRL	RETRO-FIT COLLAR	FRL	RETRO-FIT COLLAR	FRL
16mm	PROMASEAL CFC 32 <sup>1</sup>	-/180/90	PROMASEAL CFC 32 <sup>2</sup>	-/180/90	PROMASEAL CFC 32 <sup>6</sup>	-/60/60
20mm	PROMASEAL CFC 32 <sup>1</sup>	-/180/180	PROMASEAL CFC 32 <sup>2</sup>	-/180/120	PROMASEAL CFC 32 <sup>6</sup>	-/60/60
25mm	PROMASEAL CFC 32 <sup>3</sup>	-/180/90				
32mm	PROMASEAL CFC 32 <sup>4</sup>	-/180/90	PROMASEAL CFC 32 <sup>5</sup>	-/180/120		

Results based on tested pipes with wall thickness within +/- 0.5mm of manufacturers published nominal thickness.

### Reference test numbers

<sup>1</sup> WFRA 41195\_SAS.1

<sup>2</sup> WFRA 21138

<sup>3</sup> WFRA 2159700B.1

<sup>4</sup> BWA 2253500

<sup>5</sup> BWA 2253502

<sup>6</sup> FSRG A-14-947

# Fire Safety Ratings Collars for Wall Penetrations

## WATERPEX



WaterPex piping

PIPE	Fire Rated Plasterboard (128mm Thick)		Hebel (75mm)		Speed Panel (77mm)		Fire Rated Plasterboard (48mm Thick)		Fire Rated Plasterboard (96mm Thick)	
	CAST-IN COLLAR	FRL	RET-RO-FIT COLLAR	FRL	RET-RO-FIT COLLAR	FRL				
16mm	PROMASEAL CFC 32 <sup>3</sup>	-/180/180							PROMASEAL CFC 32 <sup>12</sup>	-/60/60
20mm	PROMASEAL CFC 32 <sup>4</sup>	-/180/180	PROMASEAL CFC 32 <sup>1&amp;6</sup>	-/180/120	PROMASEAL CFC 32 <sup>2&amp;7</sup>	-/120/30	PROMASEAL CFC 32 <sup>2 &amp; 7</sup>	-/90/90	PROMASEAL CFC 32 <sup>12</sup>	-/60/60
25mm	PROMASEAL CFC 32 <sup>11</sup>	-/180/180	PROMASEAL CFC 32 <sup>1&amp;6</sup>	-/180/90	PROMASEAL CFC 32 <sup>2&amp;7</sup>	-/120/120				
32mm	PROMASEAL CFC 32 <sup>5</sup>	-/180/120								

### Reference Notes / Test Numbers

<sup>1</sup> Based on two CFC32 screwed together and inserted into wall (centralised). If on each face FRL is -/120/90.

<sup>2</sup> A layer of 25mm PROMATECT -100 is attached to each face of wall before applying collar. applying collar

<sup>3</sup> WFRA41195

<sup>4</sup> WFRA 2257300.1

<sup>5</sup> FSRG A-13-852

<sup>6</sup> FSRG A-13-816

<sup>7</sup> FSRG A-12-777

<sup>8</sup> FSRG A-13-848

<sup>9</sup> FSRG A-13-823

<sup>10</sup> Based on a single CFC32 centralised in the wall

<sup>11</sup> WFRA21138-01.1

<sup>12</sup> FSRG A-14-947

# Fire Safety Ratings Collars for Slab Penetrations

## WATERPEX



WaterPex piping

	Floor / Slab			
PIPE	CAST-IN COLLAR	FRL	RETRO-FIT COLLAR	FRL
16mm	PROMASEAL CFC 32 <sup>1</sup>	-/240/120	PROMASEAL CFC 32 <sup>2</sup>	-/180/90
	PROMASEAL Green 40 <sup>1</sup>			
20mm	PROMASEAL CFC 32 <sup>1</sup>	-/240/180	PROMASEAL CFC 32 <sup>3</sup>	-/180/120
	PROMASEAL Green 40 <sup>1</sup>			
25mm	PROMASEAL CFC 32 <sup>1</sup>	-/240/180		
	PROMASEAL Green 40 <sup>1</sup>	-/120/120		
32mm	PROMASEAL CFC 32 <sup>1</sup>	-/240/120	PROMASEAL CFC 32 <sup>3</sup>	-/240/120
	PROMASEAL Green 40 <sup>1</sup>	-/180/180		

### Test Numbers

<sup>1</sup> FSRG A-11-737

<sup>2</sup> BWA2253500.1

<sup>3</sup> WFRA 2257301.1